

B4.1

:: Driver: Leigh Cheeseman

:: Date: 11/06/11

:: Track: Cairns

:: Event: Queensland State Titles.

Setup Sheet for Team Associated's B4.1

Reset Forms

Rev. 1

:: Front End

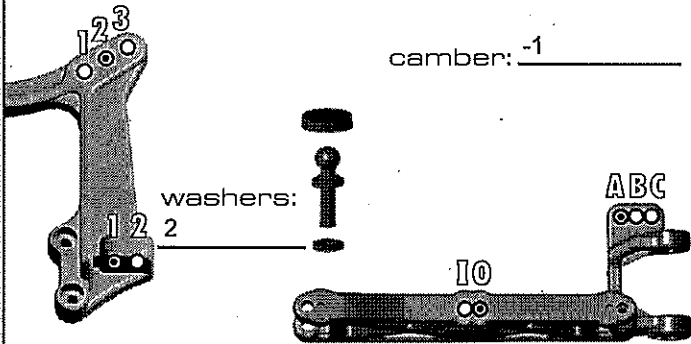

toe: -1 ride height: 24mm

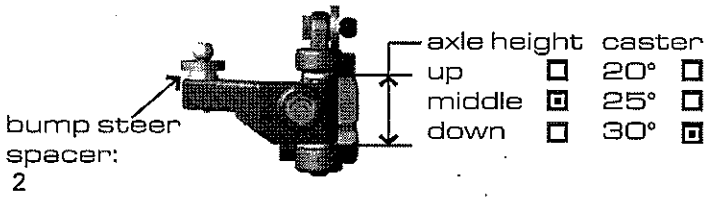

:: Rear End

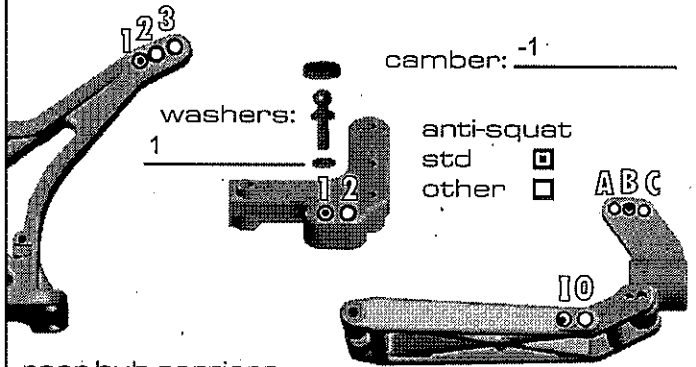

near hub carriers
std ride height: 24
0°
0.5°
1°

wheel base
long
medium
short
anti-roll bar
none
black (soft)
silver (med)
gold (hard)

:: Front Shocks

spring: brown piston: 1
shock oil: 35 losi limiter: 2

:: Rear Shocks

spring: green piston: 2
shock oil: 27.5 losi limiter: 2

:: Electronics

motor & wind: 8.5 Nosram
pinion: 24
spur gear: 81
batteries: intellect
battery placement: middle

radio: spektrum
throttle / brake epa: 100%/80%
throttle / brake expo: 0
esc: Nosram Pearl throttle profile:
initial brake: drag brake:
servo: steering expo: 0

:: Other

body: J Concepts
notes: J Concepts 7 inch wing, half cut out

:: Differential

gear differential fluid:
ball differential: tightish

:: Front Tires

tire: J Concepts Rips
compound: Green
insert: std
wheel: std

:: Rear Tires

tire: Proline Caliber - Control tire
compound: M3
insert: std
wheel: std

:: Race and Vehicle Comments

quality: 1 main: 1 finish: 1 tq:
comments: Went to Kyosho dark yellow springs later in the day with 30 Losi oil. Also moved battery to forward position later in the day.
7 grams in rear pods, 14 grams behind receiver and 14 grams in front of gear box.

:: Track Info

smooth: bumpy: blue groove:
traction: high: med: low:
soft dirt: grass: clay: wet:
dusty: other: had concrete dust watered into surface

:: For more setups, visit www.RC10.com and click on "Racing" then "Setups"